



K-Myo Electromyograph User Guide

 **KINVENT**

NOTICE

This manual concerns the K-Myo product. The information content of this manual belongs to KINVENT, and is provided only for the purpose of operating K-Myo and software. This manual is subject to modifications. The latest version is available on <https://quickstart.k-invent.com/>

NOTICE

The advice given in this manual is intended to supplement, not supersede, the normal safety requirements prevailing in the user's country

**Manufacturer**

KINVENT Biomécanique SAS
Cap omega, Rond-Point Benjamin Franklin,
34000 Montpellier, FRANCE
+33 4 67 13 00 33
info@k-invent.com,
www.k-invent.com

© Copyright 2023 **KINVENT Biomécanique SAS**.

KINVENT Biomécanique, K- SENSORS, K-Myo, its logos, and other KINVENT brand trademarks and made names are registered trademarks of KINVENT Biomécanique SAS.

All rights reserved. This material may not be reproduced by any means, physical or electronic, without prior written consent of KINVENT Biomécanique

Trademarks

Trademarks and labels used in this document are property of their respective owners

This product is protected by granted patents, pending patent applications and their corresponding national rights.

Revision: 3

Last revision: 2023-02-11





Graphic Symbol

- 

The sensors comply with electromagnetic regulations as laid out by the Federal Communications Commission.
- 

European Conformity MDR 2017/745
- 

IEC 60878 Direct Current IN
- 

Recyclable Packaging Box
- 

Keep Dry. Indicates a medical device that needs to be protected from moisture.
- 

Sensor is provided nonsterile
- 

Attention, See Instructions for use
- 

Type BF applied part - External Body only , Floating- No earth connection
- 

Indicates the manufacturer's **serial number** so that a specific medical device can be identified
- 

Indicates the **medical device legal manufacturer**, as defined in EU Directives 90/385/EEC, 93/42/EEC and 98/79/EC

- 

Sensor will not work when connected to AC outlet
- 

Class II Electrical Equipment
- 

An ISO 15223 symbol Indicating upper & lower temperature limits for operation, transport, and storage
- 

Humidity limitation. Indicates the range of humidity to which the medical device can be safely exposed.
- 

Atmospheric pressure limitation. Indicates the range of atmospheric pressure to which the medical device can be safely exposed.
- 

Non Ionizing radiation
- 

Do not dispose of the units in normal household waste. Dispose products in accordance with local regulations
Waste Electrical and Electronic Equipment (WEEE) logo
- 

WARNING General warning
- 

NOTICE General Notice
- 

Bluetooth logo. The utilizes a Bluetooth LE radio for wireless communications

Contents

Graphic Symbol	3	Equipment (WEEE) Policy	26
Contents	4	Declaration of Conformity	27
Introduction	5	FCC information	32
About us	5	Canada	32
Safety Information	5	Japan	32
Photosensitive seizure warning	5	Switzerland	33
K-Physio application 1.19	6	United Kingdom	33
Installation the Application on the Host Device	7	Contact Information	33
First Login	7		
Intended use	9		
CONTRAINDICATIONS	9		
Safety precautions	10		
Replaceable Parts	12		
General Operating Conditions	13		
Operating Environment	13		
Storage, Packaging and Transportation	13		
Calibration	13		
Cleaning	14		
Interface	15		
LED States	16		
K-Myo	17		
Description	17		
Benefits	17		
Usability Data	17		
Technical Features	18		
Get Started	19		
Accessories	20		
Content of the Commercial Package	21		
Preparation for measurement and best practices	21		
Troubleshooting	23		
Sensor difficulties	23		
Connectivity difficulties	24		
Legal information	25		
Warranty Terms	25		
European Union	25		
Other countries	25		
Obligations of the User	25		
Service policy	26		
Waste Electrical and Electronic			

Introduction

Thank you for purchasing the K-Myo.

K-Myo is part of the product line developed by KINVENT to objectively quantify rehabilitation.

About us



KINVENT is specialized in the design and manufacturing of biomechanics equipment. Our strength is that we can conceive and implement solutions to any challenge in sports biomechanics and physical rehabilitation. Our products include ready-to-use force plates, inertial wireless sensors, simulators and various custom-made applications.

Find more information on our products at www.k-invent.com.

Safety Information

The instructions and safety information in this user manual must be followed to ensure safe operation of the K-Myo. Please note that if the equipment is used in a manner not specified by KINVENT, the protection provided by the equipment may be impaired.

The following types of safety information appear throughout the Manual. Details are given in the format as shown below:

-  **WARNING** The term WARNING is used to inform you about situations that could result in serious damage to the device or other part of the System and to the environment.
-  **CAUTION** The term CAUTION is used to inform you about situations that could result in damage to the device that affect the measurement results or pose a risk to the safety of the patient/user or the operator.
-  **NOTICE** The term NOTICE is used to indicate information considered important but not hazard related (e.g., security messages, maintenance and cleaning guidelines)

Photosensitive seizure warning

WARNING

A very small percentage of people may experience a seizure when exposed to certain visual images, including flashing lights or patterns that may appear in video games. Even people who have no history of seizures or epilepsy may have an undiagnosed condition that can cause these “photosensitive epileptic seizures” while watching video games. These seizures may have a variety of symptoms, including altered vision, eye or face twitching, jerking or shaking of arms or legs, disorientation, confusion, or momentary loss of awareness. Seizures may also cause loss of consciousness or convulsions that can lead to injury.

Immediately discontinue playing and consult a doctor if you experience any of these symptoms. Parents should watch for or ask their children about the above symptoms.

K-Physio application 1.19¹

Kinvent Physio is the only app you will need for all your Kinvent Sensors. All tutorials for the Kinvent Physio app are available online at: [Kinvent.link/quickstart](https://kinvent.link/quickstart)

Minimum Requirements: Android 6.0+ or iOS 11.0+, 2GB of RAM, Bluetooth Low Energy 4.2+, 5" (12.7cm) Screen diagonal

Recommended: Android 8.0+ or iOS 16.0+, 4GB of RAM, Bluetooth Low Energy 5.0+, 6.5" (16.5 cm) Screen diagonal

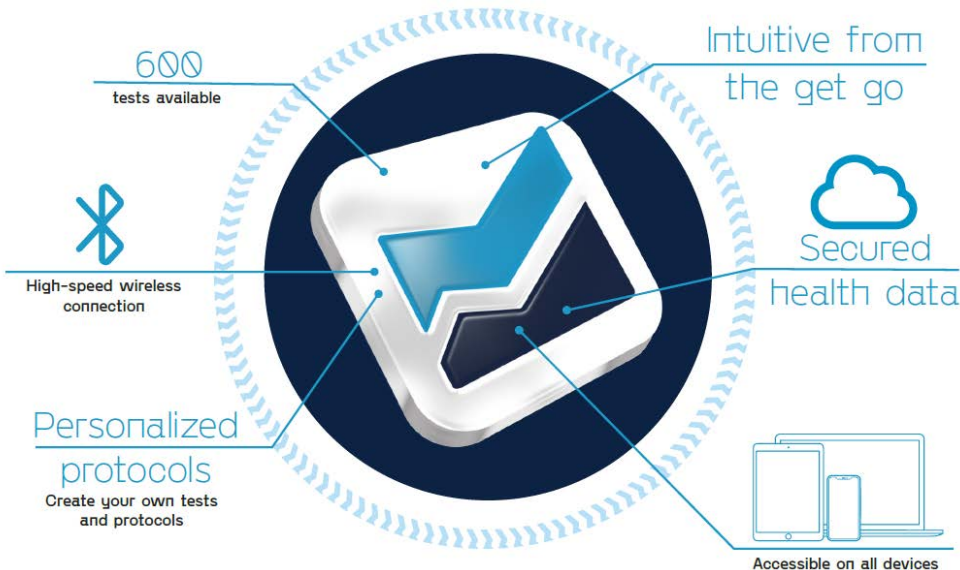
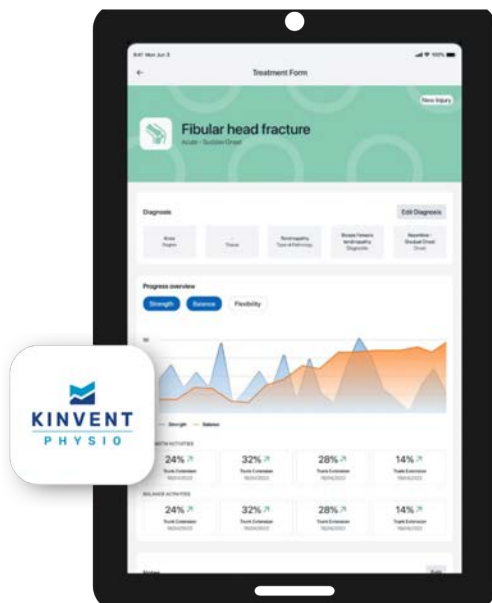

¹ Latest version may differ on the store

Installation the Application on the Host Device

Download the App from Google Play for Android Devices or App Store for iOS devices

Follow the Instruction registration on the App

Connect the Device with the App Via BLE



First Login

The K Physio App will require an initial registration and some information regarding the operator's specialty and profile to help ensure proper use.

You need to connect the K SENSORS and K-Myo with compatible Bluetooth® Low Energy (BLE) devices to store, analyze and view the measurement data. These host devices HD can be, for example mobile devices running respective host applications (K Physio) for data visualization.

The sensors can be registered in the K Physio App in order to be easily identified when starting an exercise.

You can register the devices with multiple host devices, but only one connection can be active at a time.

Full patient file

Fill in the patient’s pathology information to guide care and make their file available to all healthcare professionals in your office.

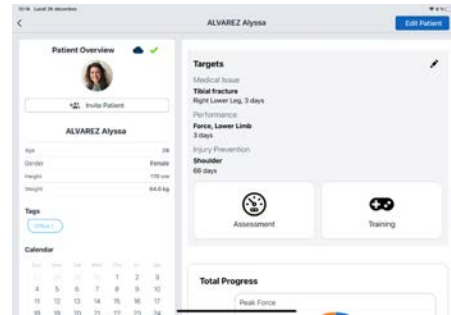

Personalized reports

Synthesize your rehabilitation results with the multiple export module.



Standard premium evaluations

Take a scientific approach to validated standard protocols: CMJ, Drop jump, Squat jump, McCall test, ASH test, squat analysis, Romberg, test profile strength, DSI, EVA, max strength, IMPT, antagonist ratio, posture analysis.

K-apture

Film your patient’s movement and synchronize it with every Kinvent Physio evaluations. Carry out qualitative analysis to integrate in your reports.

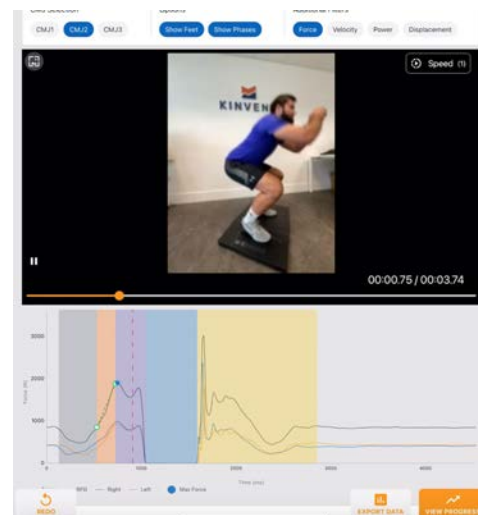

MyKinvent

Give your patient agency in their rehabilitation by giving them access to their own data.

Kinvent Connect

Centralize all your data in one place and access it from any device: smartphone, tablet, computer, etc.

Intended use

The K-Myo is intended to be used by trained professionals to assist with qualitative evaluating the muscle activity

The K-Myo may be used by medical professionals at healthcare facilities or at patient homes. The K-Myo by KINVENT must be operated by personnel familiar with electromyography and have the appropriate training

K-Myo is

- Medical Electrical Equipment
- Internally Powered Equipment (Battery operated)
- With Type BF Applied Part
- Continuous operation
- Not suitable for operation in an oxygen rich environment

The expected service life in normal use is 5 years

CAUTION

Replace the device after ending the expected service life or earlier if one of the follows occur:

- otherwise instructed or
- the harsher than normal operating conditions have caused deterioration of the essential features or
- if any damage to the device is observed (e.g., any cracks or structural damage).
- See paragraph for recycling guidance.

CONTRAINDICATIONS

The K-Myo is contraindicated under the following:

- On or near open wounds
- Patients having severe osteoporosis
- On or near burned tissue
- On or near the eye
- On or near fractures
- Not to be used for any purpose other than indicated

Safety precautions

The safety information must be read thoroughly and understood before starting the work with K-Myo

WARNING

- Take care of the strong attachment or hold of each sensor.
- Do not dispose of the K-Myo sensor in fire.
- K-Myo contains lithium-polymer batteries. *Do not dispose of the batteries with household waste*
- The K-Myo is not protected against ingress of liquids. Keep sensors dry. Do not immerse the K-Myo or their accessories in water.
- The K-Myo and accessories are provided non-sterile and are not compatible with autoclave or other sterilization techniques. Do not autoclave.
- Use only a factory supplied wall pack power supply, charger. Use of another charger may result in electrical shock or equipment damage.
- K-Myo is not intended for use while attached to a wall pack power supply or a charger. Never attempt to operate the instrument while it is connected to the charger as electrical shock or damage to the instrument may occur.

WARNING

DO NOT USE ON Patients with Silver allergies.

WARNING

DO NOT USE on irritated skin or open wounds.

WARNING

Immediately discontinue device use if skin irritation or discomfort occurs.

CAUTION

- Only use the device in your existing environment during your daily routine activities. Do not use the device during enhanced or irregular activities or outside your natural environment, unless specifically instructed otherwise by your doctor or physical therapist.
- Do not drive or operate heavy machinery while wearing the device.
- Users with disabilities (e.g neurological disorders, osteoporosis), which may cause contraindications, or users for whom exercise may be extremely dangerous, must take precaution to ensure their safety when using the device (e.g., supervision, etc.).
- Do not use the device if you suspect that it is faulty or has been damaged. Do not try to repair the device on your own.

- Report any change in your medical condition that is related to the diagnosis or treatment to your doctor or physical therapist.
- Do not give, sell, rent or allow the use of your device to or by another person.
- Stop the use of the system immediately if parts are damaged or if a change in the performance is observed.
- Stop the use of the system immediately if an allergic reaction is observed.
- Do not modify this system without prior written authorization of the manufacturer. If this system is modified, appropriate inspection and testing must be conducted to ensure continued safe use of the system.
- Always consult your doctor if you have a medical condition and before beginning a program.
- Always consult your doctor before using the device if you have a pacemaker or other implanted device. Although several implanted pacemaker manufacturers state the risk associated with the simultaneous use is low, it is essential to consult a doctor who knows the exact type and model of the implanted device in question before using the system. In any case keep the device at least 15cm (6") away from the implanted device.
- Do not use the device during magnetic resonance imaging (MRI), unless specifically approved by the personnel operating the MRI equipment. The battery inside the device is sensitive to magnetic fields.
- The device is not for multiple users if consequences from possible cross contamination may be severe. Careful cleaning and disinfection are recommended to prevent cross infection if used by multiple users.
- The conductive parts of the device must not be allowed to contact any conductive parts, including protective earth connection.
- Keep the device and any part of the system away from the reach of children, pets or pests when not in use.
- Portable RF communications equipment (including peripherals such as antenna cables and external antennas) should be used no closer than 30 cm (12 inches) to any part of the system. Otherwise, degradation of the performance of this system could result.
- Use of this system adjacent to or stacked with other equipment should be avoided because it could result in improper operation. If such use is necessary, this system and the other equipment should be observed to verify that they are operating normally.
- If the storage temperature is below 0°C , allow the parts of the system internal temperature to stabilize for at least 30 min before use. Be aware of condensation
- If the part of the system is to be used in an environment prone to dirt build-up, clean the device regularly. For cleaning, please follow the instructions provided in paragraph "Cleaning".
- Use the system at least 30 cm (12") away from the sources of power line frequency magnetic fields, radio frequency communications equipment and other sources of radio frequency signals (such as radars or microwave ovens).

- If the measurement results are fluctuated by a strong nearby radio frequency disturbance source, move further away from the source of the radio frequency disturbances.
- Avoid using the system in the proximity of electrostatic disturbance sources. Do not use close to a 2.4GHz signal source, as strong signals may negatively affect the performance of the radio link.
- Prior to each use of the device you may want to re-check and confirm that parts are properly attached.
- Should any problem occur as a result of the device, you are advised to discontinue use immediately and contact your doctor or physician immediately
- Contact the manufacturer in case assistance is needed in setting up, using or maintaining the device or to report unexpected operation or events.
- The K-Myo should only be used by trained professionals.
- The K-Myo is a medical sensor. The sensors should be treated with care. Do not drop, bang, hit or subject the sensors to strong shock . Be careful to have a firm grip when holding sensors in order to avoid accidental fall of the system which may cause damage to the sensor or injury to the patient/operator.
- Not recommended for use in extreme temperatures, high humidity, or direct sunlight
- Ensure your patient is able to keep his balance while watching the screen to avoid fall
- Sensors are not known to contain any hazardous materials. For proper disposal instructions, consult your local waste management facility. E-waste recycling should be used where available.
- Do not service the battery while in use with a patient.
- Never disassemble or modify the system using any accessories not specifically approved by KINVENT Biomécanique, LLC, this will void the warranty as well as reduce immunity to electromagnetic interference, or increase electromagnetic emissions, and result in improper operation.
- Don't place any K-Myo components on unstable surfaces, or surfaces subject to vibration.
- Medical Electrical Equipment needs special precautions regarding EMC. K-Myo needs to be installed and put into service according to the information provided in this manual.

Replaceable Parts

- Holder
- Straps
- Accessories

General Operating Conditions

Operating Environment

K-Myo must be used indoors. K-Myo must be used only in clean, dry rooms with leveled floors. Make sure you have plenty of space around you when you use it.

Storage, Packaging and Transportation

Temperature:
-10 °C to 40 °C
(14 °F to 104 °F)

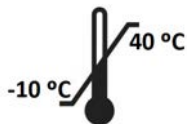

Pressure :
70kPa to 106kPa

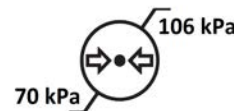

Air Humidity:
30 % to 75 %



When not in use, please store it in the protective carrying pouch.

If the K Myo is stored for longer than 30 days, check battery level and recharge if necessary before using.

CAUTION

Please observe the storage conditions and never store them in an automobile except when transporting them.

Calibration

K-Myo gives you measurements of muscle activity. K-Myo is already calibrated, to make it ready for use out of the box.

We recommend that the product be tested for calibration at least once a year under normal use or sooner under severe conditions and usage. K-Myo are not user serviceable and do not include a service manual. For more information on calibration as well as special requirements, please contact your K-Myo dealer.

Cleaning

NOTICE

The cleaning paragraph must be read thoroughly and understood before starting the cleaning work.

K-Myo should be cleaned after each use. Cleaning and disinfection of the K-Myo can be performed by the system operator or the patient/user.

In order to clean the K-Myo's housing, use a damp cloth moistened with water or a mild detergent. If the dirt is persistent, rub the surface of the K-Myo with a cloth moistened with ethanol-based disinfectant or with 70% alcohol solvent. Do not use aggressive cleaning agents such as acetone.

For more persistent stains and for disinfecting the K-Myo **Low level or intermediate level disinfectants should be used (e.g. alcohol wipes). Do not use bleach to clean the plastic parts, prefer alcohol blends**

Do not use objects that could damage or scratch the surface.

If the inside of the K-Myo is contaminated, contact your local distributor or KINVENT support directly.

⚠ WARNING

Careful cleaning and disinfection by the operator are recommended between uses to prevent cross infection if worn by multiple users or patients. Disinfect before and after each use. Allow disinfectants to dry before taking into use. Not to be worn by multiple users if consequences of cross contamination may be severe.

NOTICE

Repetitive disinfection with ethanol-based disinfectant may in the long run cause aging and discoloration of the case used. Discoloration does not affect safe use. If any cracks or structural damage is observed, replace the device .

Interface

- 1- Multi color LED
- 2- USB-C charge port
- 3- Power on/ Command orange button
- 4- 3.5mm jack for connecting to external leads to Channel 2
- 5- Snap in connector for electrodes of Channel 1

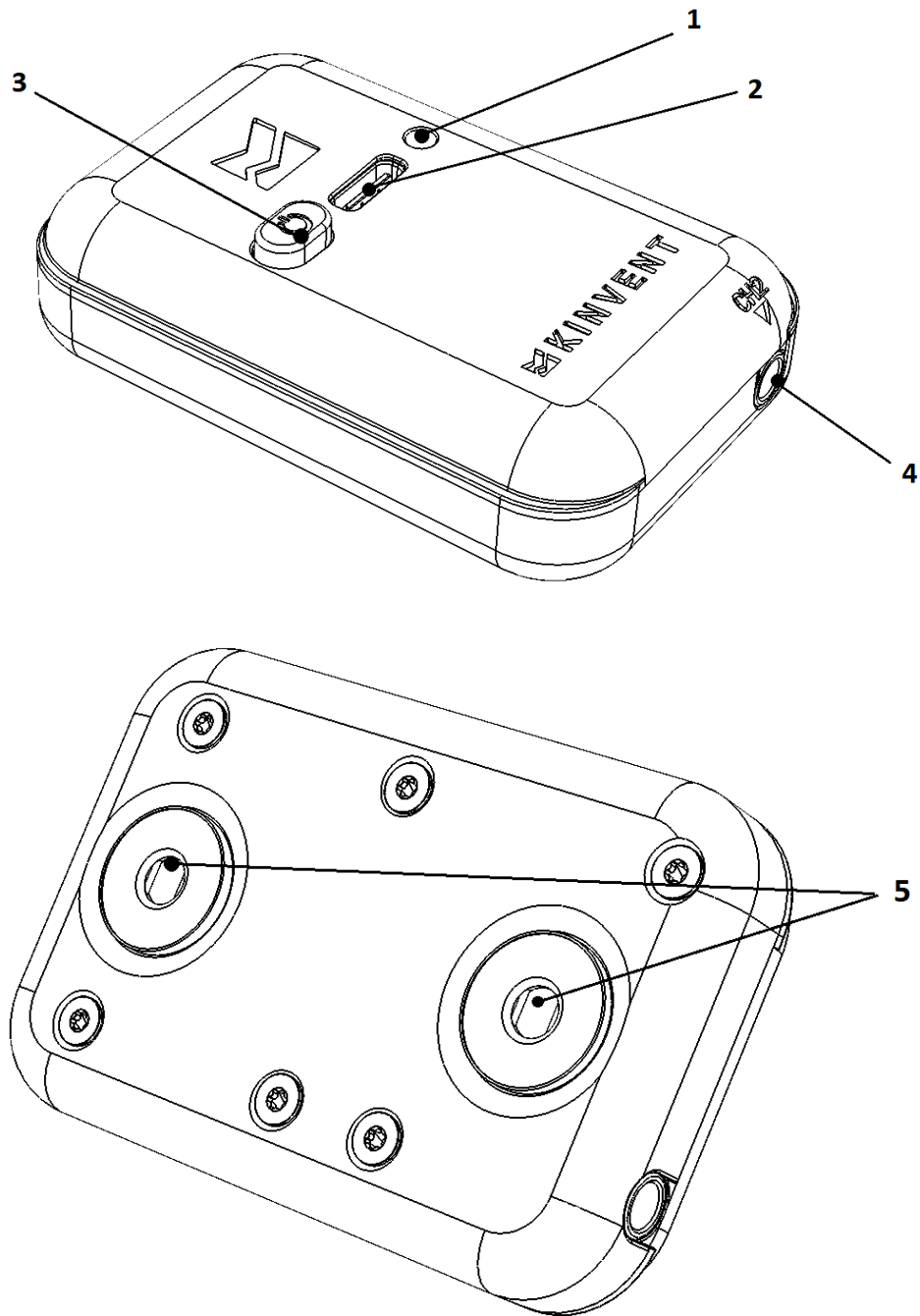

LED States

- When the sensor is connected via USB, the sensor will turn on (**GREEN** flashing LED) and begin to charge the internal battery.
- After 10 min, if not connected to the application, it will automatically power off. The battery will continue to charge indicated by a pulsing **ORANGE** light.
- Once the battery reaches full charge the sensor will indicate this by switching to permanent **WHITE** light. If power is removed the sensor will power on again.
- The sensor can wake by plugging in the USB cable or pushing the orange button. The **GREEN** led starts blinking.
- When a successful connection over Bluetooth is attained then the light begins flashing **BLUE**
- If the battery is low, then a **RED** light will flash intermittently three times and every 5 seconds. Wireless range may be affected if operating under this condition.
- The sensor will switch off if the battery voltage is lower than 1%.
- A single push on the button will display the battery status via bright **red, yellow, or green** light depending on charge level.

Visual	LED Functionality	Explanation	Action requested
	LED is OFF	Sensor is OFF	Press the button to power on the sensor
	GREEN LED is Blinking	Sensor is ON	Normal operation - Sensor is ready to connect
	BLUE LED is Blinking	Sensor Connected	Sensor is connected to the app (tablet/phone)
	ORANGE LED Slow blink	Sensor is OFF and charging	None- the sensor will continue charge until full
	WHITE LED is lit steady	Sensor has reached End of charge	Internal battery is 100%, please remove charging cable
	RED LED is blinking (three blinks intermittently)	Sensor has low battery (<10%)	Please charge the sensor
Action	LED behavior	Explanation	
Button pressed once during ready or connected state	Steady lit LED color Green, Yellow or Red	Battery state of charge Green : 71 to 100% Yellow : 31 to 70% Red : <30%	
Button pressed once during a "Start screen" in the app	Steady lit LED color Green, Yellow or Red	Will also start the training/exercise selected or switch sides depending on the app message	



K-Myo

Description

K-Myo is used for the evaluation of the activation of a muscle during training. K-Myo qualitative measures the muscle effort caused during training

Benefits

K-Myo is an electromyography tool that measures the biopotential and gives you real-time biofeedback on your tablet or smartphone through the Kinvent Physio app. Therefore, you can set strength objectives for your patient and motivate him through the process of rehabilitation. You will, then,

follow-up your patient's progress through the Kinvent Physio interactive database.

Usability Data

Intended medical indication:

For the evaluation of different muscle activation levels

Intended patient population

Teenagers to geriatric, with normal health or pre/post operation only on doctor's approval for rehabilitation.

Intended part of the body or type of tissue to or interacted with:

Site: External areas , typically arms, hands, torso, head, legs, feet

Condition: Normal, no abscesses nor wounds.

Direct contact via metallic pads (silver) or gel type pads

Intended User Profile:

The K-Myo must be used by a trained health professional. The user must have received sufficient training in clinical procedures to get reliable measurements.

Intended use environment :

Hospital or other medical practice environment.

Operating Principle:

K-Myo is equipped with an electronic converter that measures the muscle activation signals in the mV range and amplifies them for them to be measured.

Technical Features

Dimensions and Weight

Weight	37 g / 1.30 oz with holder 30 g / 1.05 oz device only
Dimensions (H x W x L)	Metric : 60 x 40 x 16.5mm With holder 64 x 57 x 16.5 mm
Channels	2 (1 internal, 1 external via 3.5mm jack) External channel contains a bias channel
Gain	Software selectable 6,8,12,24
Acquisition frequency	1000Hz
Eco features	Self-activated "sleep" mode after 10 minutes.

Electrical and Communication Data

Radio Technology	Bluetooth Low Energy 5.1
Power supply	1 cell 3.7V Li-Po Battery 200mAh
Radiated output power	Max.10 mW
Wireless transmission Frequency	2.4 GHz band 2402- 2480 MHz
Modulation	GFSK
Channel Bandwidth	2 MHz
ERP	8.6dbm
Wireless range	Up to 40 meters / 44 yd
Contains FCC ID	2AAQS-ISP1807
Input Differential range	750mV (at 6 Gain) , 187mV (24 Gain)
Input Protection	ESD 12kV, Current limiting
ADC, sampling and bandwidth	24 bit ADC, up to 2000 Hz , Bandwidth 10-1061 Hz Channel 1 Bandwidth 0-1061 Hz Channel 2 (use of external Bias lead)
Battery	12h of autonomy, 2h for charging
Minimum requirements	Android 6.0+ or iOS 11.0+, Bluetooth Low Energy

Get Started

On the top surface of the sensor there are : one USB-C port used for charging, one LED indicator for the working state/charging state and one push-button.

You can charge your K-Myo sensor through the USB A to USB C cable provided or with any USB-C charging cable. The sensor is supplied with the appropriate IEC 60601 medical USB power supply. If a different charger is used, ensure that it meets the minimum medical safety requirements and if unsure please do not use the sensor while plugged in/charging.

WARNING

Disinfect K-Myo prior to use. Low level or intermediate level disinfectants should be used (e.g. alcohol wipes). Do not use bleach to clean the plastic parts, prefer alcohol blends

Press the orange power on button on K-Myo. The indicator begins flashing green. Your sensor is ON! Your sensor will turn off after 10 minutes of no Bluetooth connection or no application connection.

Once the sensor is turned on, select the K-Myo sensor activity in the Home Page. At this step, the K-Myo is connected and the LED starts flashing Blue.

NOTICE

While your K-Myo is connecting, don't touch the EMG leads.

Accessories

The K-Myo is provided with the following accessories

- Strap and holder

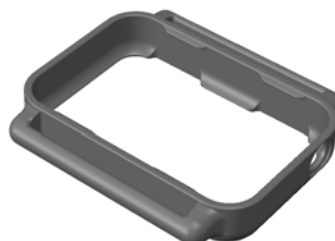

- Single use patches with snap connector
Ø 35 mm

Kendall EKG adhesive electrode H135SG -
diameter of the electrode 24 mm
50 electrodes per bag
Ag / AgCl sensor - embedded in an adhesive
and conductive liquid hydrogel
The carrier material is foam (adhesive) -
suitable for sweaty patients
Good long-term adhesive strength -
experience has shown that it is very suitable
for use in the sleep laboratory for EKG, EOG
and EMG.



REF: 31.1355.21

- Multi-use AgCL snap pads



- Reusable triple strap with leads and a 3.5mm jack for use with the secondary channel (CH2)
 - Left, Right, and Bias channels



- EMG leads with 3 snap-on connectors and a 3.5mm jack for use with the secondary channel (CH2)
 - Silicone rubber
 - Shielded
 - 3.5mm phone jack connector
 - Length: 80 cm or 60 cm
 - Left, Right, and Bias channels



Content of the Commercial Package

The User will receive:

- K-Myo
- Medical grade power adapter with USB-A for charging
- USB-C to USB-A charging/data cable
- Quick start cards in EN/ FR /ES
- User manual

The battery is not removable, it is already installed in the device

Sold separately

- Accessory pack with 1x holder, 100 patches, 1 reusable strap, 1x set of EMG leads, 2x reusable snap pads

Preparation for measurement and best practices

- Ensure a good electrode/skin contact. Using the gel electrodes provides a higher quality signal and reduces unwanted noise sources and position changes or sporadic contact due to debris, hair or dirt. If an enhanced signal is needed, the area must be shaved off and the skin cleaned and sanitized to remove oil sweat and dirt.
- Sampling rate of 1000 Hz is recommended
- External wire length should be minimized (in case of use of Ch2) since the EMG voltage is very low. Motor or power lines will cause interference (50/60Hz). Mains notch filtering is applied by default on the signal to reduce the effect, but it is recommended to stay at least a few meters away from such sources.
- Wires need to be secured to reduce noise due to movement as well as reduce the risk of falls /tripping during movement

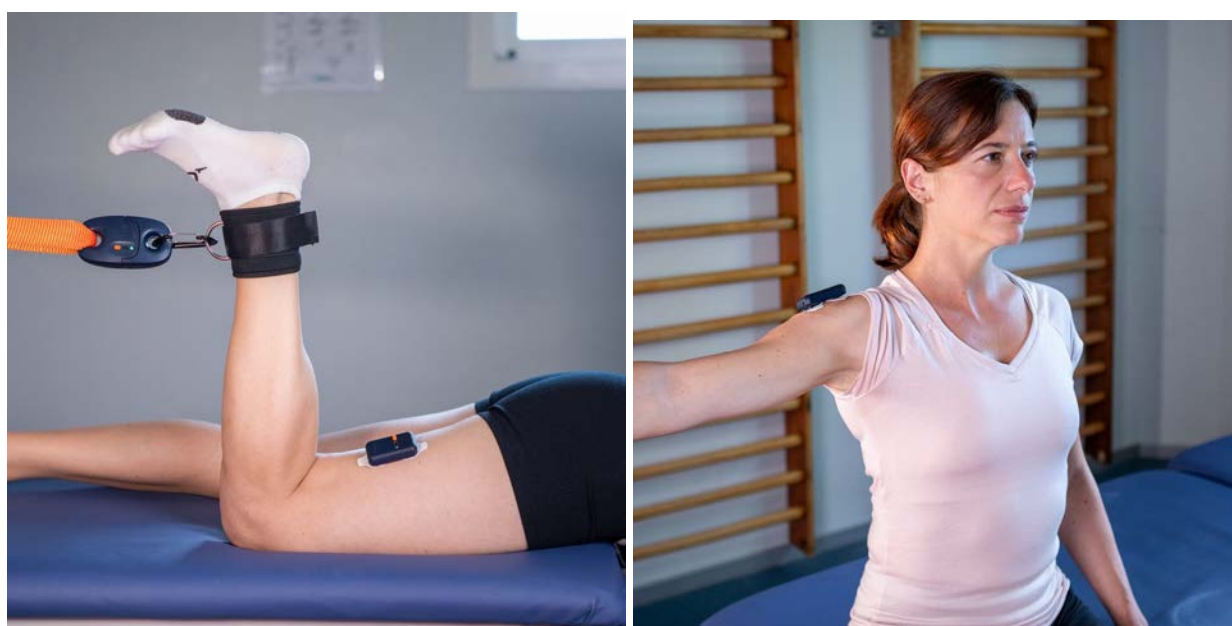

Figure 1 (left) use with link on hamstrings, (right) use with belts on shoulder

Available assessments	Muscle	Device
Leg Extension / Isometric contraction	Quads assessment	K-Myo
Leg Flexion / Isometric contraction	Hamstrings assessment	K-Myo
Grip	Flexors assessment	K-Myo
Shoulder Abduction	Deltoids assessment	K-Myo
Leg Extension	Quads assessment	K-Myo + K-Pull
Leg Flexion	Hamstrings assessment	K-Myo + K-Push
Shoulder Abduction	Shoulder assessment	K-Myo + K-Push
Grip	Brachioradialis assessment	K-Myo + K-Grip

Troubleshooting

If any difficulties occur while using the system check if the symptoms appear in the following list. For further assistance please visit KINVENT's Help Center at [Kinvent.link/quickstart](https://kinvent.link/quickstart) or use the Kinvent Physio app assistance menu: "support".

Sensor difficulties

Symptom	Actions
The sensor isn't turning on	<ol style="list-style-type: none"> 1. Connect a known working charger with a known working USB cable and charge the sensor for a minimum of 30 min. Plug and unplug the usb cable, an orange or green light should come on after a short while. 2. Press the On/Off button until an audible click is heard and felt. 3. If you suspect failure, contact your distributor or check our website for the replacement scheme or contact directly using the K PHYSIO assistance menu
While having closed the app, the sensors keeps the Blue LED on	<ol style="list-style-type: none"> 1. Make sure the app is closed. On Android hold the "Home" button or press the "Recently Used Apps" button to view the list of running apps. To close the app, swipe it to the left or to the right 2. Turn off the Bluetooth on the tablet or smartphone sensor. 3. Press the on/off push button for 5 sec to force it to turn off
The sensor isn't shutting down after 10 minutes of inactivity	<ol style="list-style-type: none"> 1. Check if an active connection is on (indicated by blue light) and close the application/bluetooth. Press optionally the on/off push button for > 5 sec to force shut down the sensor. 2. Make sure that no load is applied on the sensor. 3. If the issue persists, you can use the on-screen instruction on the app for resetting the baseline.
A calibration error message is shown.	<ol style="list-style-type: none"> 1. Close the app and try again while making sure that no load is applied on the sensors. For K-Force Plates / K-Deltas make sure the surface is flat and all feet are in contact with the ground and the platform does not wobble. For K-Move please do not move/bump the sensor while calibrating. 2. Contact KINVENT for scheduling a calibration. Calibration should be performed annually or sooner if special conditions apply.
A part is damaged/ lost	<ol style="list-style-type: none"> 1. Please contact KINVENT to arrange a replacement spare part.

Connectivity difficulties

Symptom	Actions
The sensor is turned on but isn't connecting.	<ol style="list-style-type: none"> 1. Make sure your smartphone or tablet is compatible with K Physio. 2. Check if Bluetooth and location services are enabled, on your tablet or smartphone 3. Check if the sensors are properly charged - pressing the button should light up the LED indicator and pressing a second time will bring a steady light indicating the battery charge level, make sure that it is green or orange. 4. Restart the app. On Android hold the "Home" button or press the "Recently Used Apps" button to view the list of running apps. To close the app, swipe it to the left or to the right 5. Restart your tablet or smartphone. 6. Make sure your sensor is close to your tablet or smartphone ideally no more than 5 meters/ 5.5 yd . 7. Don't pair manually the K-sensor in the Bluetooth settings of the tablet, otherwise please unpair immediately
The sensor lost connection during training	<ol style="list-style-type: none"> 1. Do not plug the USB C from the sensor to a computer or smartphone for charging during training. Only use the supplied or equivalent USB charger.
While connecting the app is showing a gray or red circle on the sensor	<ol style="list-style-type: none"> 1. Please turn off the sensor and try again. 2. Make sure that you are within range while using of the sensors 3. The official Bluetooth specifications state seven is the maximum number of Bluetooth sensors that can be connected at once. However, three to four sensors is a practical limit, depending on the sensor. Make sure that no other Bluetooth sensors (headphones/speakers etc.) are connected.
After connection , Green led is still flashing.	<ol style="list-style-type: none"> 1. Use the sensor registration menu in the application to identify using the serial number of the sensor the correct sensor. Another sensor is possibly nearby. 2. Check if other sensors are in the near area and either allow them to turn off or manually power them off. 3. In case of K Plates/ K- Deltas please verify that both a left and right sensor is present and powered on.

Legal information

Warranty Terms

This warranty shall not apply if the product

- is used with non-compatible products
- is used for commercial purposes such as rental
- is modified
- is damaged by accident, misuse, wear, or any other cause not related to defectiveness of materials or fabrication.

A valid proof of purchase in the form of a bill of sale or receipt must be provided to obtain warranty services.

KINVENT excludes all liability for any data loss, loss of profit or any other loss or damage suffered by the end customer.

European Union

K-Myo is warranted for its electronics and all mechanical components for a period of 2 years from the purchase date when used in accordance with the present manual. KINVENT can proceed to replace a K-Sensor covered by the warranty free of charge. The warranty is invalid in case of modification or replacement of any component in a K-Sensor, made without the KINVENT's authorization or the authorized K-Myo dealer's authorization. KINVENT doesn't guarantee any therapeutic result when using K-Myo. You must contact KINVENT or your authorized dealer to receive a return authorization and shipping instructions.

Other countries

K-Myo is warranted for its electronics and all mechanical components for a period of 1 year from the purchase date when used in accordance with the present user's manual. KINVENT can proceed to replace a K-Sensor covered by the warranty free of charge. The warranty is invalid in case of modification or replacement of any component in a K-Sensor, made without the authorization of KINVENT or the authorized K-Myo dealer. KINVENT doesn't guarantee any therapeutic result when using K-Myo. You must contact KINVENT or your authorized dealer to receive a return authorization and shipping instructions.

Obligations of the User

Except in case of damage or defect attributable to KINVENT Biomecanique, the user shall not make any claims against KINVENT or their subsidiaries for any damaged or defective products or components. The user shall carefully examine the condition of the products immediately upon receipt.

If instructions given by KINVENT Biomecanique with respect to storage, installation and handling of the products are not observed or if changes are made to the product, if components are replaced or if consumable items are used which do not comply with the original specifications, any warranty rights are forfeited unless the user is able to refute any assertion that only any of these circumstances has caused the deficiency.

Defects, incorrect deliveries, quantities, or transport damage are to be notified without delay by the user in writing, by fax, or by email (in case of defects which can be identified immediately) to the KINVENT Biomecanique's distributors or to KINVENT Biomecanique directly, otherwise within two weeks of receipt of the products at the place of destination, by clearly describing the defect; in this respect, it is necessary that the user properly fulfills his obligations of investigation and notification.

In case you need to return one or multiple K-Myo, the sensors and accessories must be decontaminated and free of infectious material in order to be handled safely in a non-biological safety laboratory (see Cleaning instructions on each sensor).

The K-Myo must be returned in the original packaging. If not available anymore please inform the support or authorized distributor.

How to repackage for a return

- Pack the sensor in the original packaging (or bubble wrap if original packaging not available)
- Print and fill the after-sales service form
- Pack the sensor + form in a package
- Stick the return voucher on the package and ship

Are considered as signs of material degradation

- Scratches
- Broken parts due to drops or inappropriate uses
- Modification or replacement of any component
- Wet environment exposition
- Underwater immersion
- Extreme temperature exposition

Service policy

You acknowledge that any time your K-Myo product is serviced, this service may change your settings or cause loss of data or of some functionalities. Backup your data (stored on your tablet or smartphone) on a regular basis.

⚠ WARNING

K-Myo is a medical sensor. K-Myo must be used according to the present User's Manual and its recommendations. Failure to do so may result in personal injury.

Users are responsible for their exercise manner and the manner in which they use K-Myo. Movement promoted by K-Myo can be associated with risks of injury.

Consult on a regular basis KINVENT's website for available information on contraindications, risks or side effects concerning K-Myo. Kinvent doesn't offer treatment advice or any medical diagnosis.

In case you are currently under medication, injured or in delicate medical condition, consult a qualified professional prior to the use of any K-Myo product. .

KINVENT doesn't guarantee any therapeutic result when using K-Myo.

Waste Electrical and Electronic Equipment (WEEE) Policy

This section provides information about disposal of waste electrical and electronic equipment by users in the European Union.

The European Directive 2012/19/EC on WEEE requires proper disposal of electrical and electronic equipment when it reaches its end of life. The crossed-out wheeled bin symbol (see below) indicates that this product must not be disposed of with other waste; it must be taken to an approved treatment facility or to a designated collection point for recycling, according to local legislation. The separate collection and recycling of waste electronic equipment at the time of disposal helps to conserve natural resources and ensures that the product is recycled in a manner that protects human health and the environment



KINVENT accepts its responsibility in accordance with the specific WEEE recycling requirements and, where a replacement product is being supplied by KINVENT, provides free recycling of its WEEE-marked electronic equipment in Europe. If a replacement product is not being purchased from KINVENT recycling can be provided upon request at additional cost. To recycle electronic equipment, contact your local distributor for the required return form. Once the form is submitted, you will be contacted by the distributor either to request follow-up information for scheduling collection of the electronic waste or to provide you with an individual quote.

Declaration of Conformity

K-Myo is:

Class I medical devices per Annex IX of MDR 2017/745 , Rule 1

K-Myo is a biofeedback device and

Class I medical devices per CFR Title 21 Part 882 Subpart B, Sec. 882.5050

K-Myo also meet the following Technical Standards, to which Conformity is declared:

IEC 60601-1:2005, + AMD1:2012 +AMD2:2020	Medical electrical equipment - part 1: General requirements for basic safety and essential performance
IEC 60601-1-11:2015 + AMD1:2020	Medical Electrical Equipment - part 1-11: General requirements for basic safety and essential performance. Collateral standard: requirements for medical electrical equipment and medical electrical systems used in the home health care environment
60601-1-2:2014+A1:2020	Medical electrical equipment - part 1-2: General requirements for basic safety and essential performance. Collateral standard: electromagnetic disturbances. requirements and tests
CISPR 11:2015+ A1:2016+A2:2019	Radiated emissions Group 1, class B
IEC 61000-3-2: 2019+A1:2021,	Harmonic Current Emissions
EN 61000-3-3:2013 +A2:2021,	Voltage Fluctuations and Flicker
IEC 61000-4-2:2008	ESD immunity, ±8kV contact, ±2, ±4, ±8, ±15kV air
IEC 61000-4-3:2006 +A1:2007+A2:2010,	Radiated field immunity 80 MHz - 2.7 GHz, 10 V/m
IEC 61000-4-4:2012,	EFT/B Immunity
IEC 61000-4-5:2014 +A1:2017	Surge Immunity
IEC 61000-4-6:2013,	Conducted RF Immunity
IEC 61000-4-8:2009,	Power Frequency Magnetic Field Immunity: 30A/m 50 and 60 Hz
IEC 61000-4-11:2004 +A1:2017	Voltage Dips

KINVENT K-Myo is designed and manufactured in a facility certified to the following international standards:
EN ISO 9001:2015

KINVENT products are subject to the quality standards within the quality management system according to ISO 13485::2016

Guidance and Manufacturer’s Declaration - Electromagnetic Emissions		
The K-Myo is intended for use in the electromagnetic environment specified below. The customer or user of the K-Myo should assure that they are used in such an environment.		
Emissions Test	Compliance	Electromagnetic environment- guidance
RF emissions CISPR 11	Group 2	The K-Myo device uses RF energy only for its internal function. Therefore, its RF emissions are very low and are not likely to cause any interference in nearby electronic equipment.

Guidance and Manufacturer’s Declaration - Electromagnetic Immunity			
The K-Myo is intended for use in the electromagnetic environment specified below. The customer or user of the K-Myo should assure that they are used in such an environment.			
Immunity Test	IEC 60601 Test level	Compliance level	Electromagnetic environment- guidance
Electrostatic discharge (ESD) IEC-61000-4-2	± 8 kV contact 2, 4, 8 , 15 kV air	± 8 kV contact 2, 4, 8 , 15 kV air	Floors should be wood, concrete or ceramic tile. If floors are covered with synthetic material, the relative humidity should be at least 30 %.
Power frequency (50/60 Hz) magnetic field IEC 61000-4-8	30 A/m	30 A/m	Power frequency magnetic fields should be at levels characteristic of a typical location in a domestic environment.
NOTE UT is the AC mains voltage prior to application of the test level			

Guidance and Manufacturer’s Declaration - Electromagnetic Immunity

The K-Myo is intended for use in the electromagnetic environment specified below. The customer or user of the K-Myo should assure that they are used in such an environment.

Immunity Test	IEC 60601 Test level	Compliance level	Electromagnetic environment- guidance
Radiated RF IEC 61000-4-3	3V/m 0.15 to 80MHz 6V/m 0.15 to 80MHz and 80% AM@ 1kHz 10V/m from 80MHz to 2.7GHz	3V/m 0.15 to 80MHz 6V/m 0.15 to 80MHz and 80% AM@ 1kHz 10V/m from 80MHz to 2.7GHz	Portable and mobile RF communications equipment should be used no closer to any part of the K-Myo, including cables, than the recommended separation distance calculated from the equation applicable to the frequency of the transmitter. Recommended separation distance $d = \frac{3.5}{V_1} \sqrt{P}$ $d = \frac{12}{V_2} \sqrt{P}$ $d = \frac{12}{E_1} \sqrt{P} \quad 80\text{MHz to } 800\text{MHz}$ $d = \frac{23}{E_1} \sqrt{P} \quad 800\text{MHz to } 2.5\text{GHz}$ where P is the maximum output power rating of the transmitter in watts (W) according to the transmitter manufacturer and d is the recommended separation distance in meters (m). Field strengths from fixed RF transmitters, as determined by an electromagnetic site survey ^a , should be less than the compliance level in each frequency range ^b . Interference may occur in the vicinity of equipment marked with the following symbol: 

NOTE 1 At 80 MHz and 800 MHz, the higher frequency range applies.
 NOTE 2 These guidelines may not apply in all situations. Electromagnetic propagation is affected

by absorption and reflection from structures, objects, and people.

^a Field strengths from fixed transmitters, such as base stations for radio (cellular/cordless) telephones and land mobile radios, amateur radio, AM and FM radio broadcast and TV broadcast cannot be predicted theoretically with accuracy. To assess the electromagnetic environment due to fixed RF transmitters, an electromagnetic site survey should be considered. If the measured field strength in the location in which the K-Myo is used exceeds the applicable RF compliance level above, the K-Myo should be observed to verify normal operation. If abnormal performance is observed, additional measures may be necessary, such as re-orienting or relocating the K-Myo.

^b Over the frequency range 150 kHz to 80 MHz, field strengths should be less than V_1 v/m.

Recommended separation distances (in m) between portable and mobile RF communications equipment and the K-Myo

The K Myo is intended for use in an electromagnetic environment in which radiated RF disturbances are controlled. The customer or the user of the K-Myo can help prevent electromagnetic interference by maintaining a minimum distance between portable and mobile RF communications equipment (transmitters) and the K-Myo as recommended below, according to the maximum output power of the communications equipment.

Rated maximum output power of transmitter Watt	Separation distance according to frequency of transmitter			
	150 kHz to 80 MHz outside ISM bands	150 kHz to 80 MHz outside ISM bands $d = \frac{12}{V_2} \sqrt{P}$	80 MHz to 800MHz $d = \frac{12}{E_1} \sqrt{P}$	800 MHz to 2.5GHz $d = \frac{23}{E_1} \sqrt{P}$
0.01	0.12	0.2	0.4	1
0.1	0.37	0.64	1.3	2.6
1	1.17	2	4	8
10	3.7	6.4	13	26
100	11.7	20	40	80

For transmitters rated at a maximum output power not listed above, the recommended separation distance d in meters (m) can be estimated using the equation applicable to the frequency of the transmitter, where P is the maximum output power rating of the transmitter in watts (W) according to the transmitter manufacturer.

NOTE 1 At 80 MHz and 800 MHz, the separation distance for the higher frequency range applies.

NOTE 2 These guidelines may not apply in all situations. Electromagnetic propagation is affected by absorption and reflection from structures, objects, and people.

Test specifications for ENCLOSURE PORT IMMUNITY to RF wireless communications equipment

Test frequency (MHz)	Band (MHz)	Service	Modulation	Maximum power (W)	Distance (m)	Immunity Test Level (V/m)	Compliance level (V/m)
385	380-390		Pulse Modulation 18	1.8	0.3	27	27

			Hz				
450	430-470		FM +-5 KHz deviation	2	0.3	28	28
710	704-787	LTE band 13, 17	Pulse modulation 217 Hz	0.2	0.3	9	9
745							
780							
810	800-960	LTE band 5	Pulse modulation 18 Hz	2	0.3	28	28
870							
930							
1720	1700-1990	LTE band 1, 3, 4, 25	Pulse Modulation 217 Hz	2	0.3	28	28
1845							
1970							
2450	2400 - 2570	Bluetooth, WLAN, 802.11 b/g/n RFID 2450 LTE band 7	Pulse modulation 217 Hz	2	0.3	28	28
5240	5100 - 5800	WLAN 802.11 a/n	Pulse Modulation	0.2	0.3	9	9
5500							
5785							

FCC information

K-Myo is a product using certain radio-frequencies during functioning. All K-Myo equipment has been tested and found to comply with the limits for a Class B digital sensor, pursuant to part 15 of the FCC Rules. These limits are designed to provide reasonable protection against harmful interference in a residential installation. This equipment generates, uses and can radiate radio frequency energy, and if not installed and used in accordance with the instructions, may cause harmful interference to radio communications. However, there is no guarantee that interference will not occur in a particular installation. If this equipment does cause harmful interference to radio or television reception, which can be determined by turning the equipment off and on, the user is encouraged to try to correct the interference by one or more of the following measures:

- Reorient or relocate the receiving antenna.
- Increase the separation between the equipment and receiver.
- Connect the equipment into an outlet on a circuit different from that to which the receiver is connected.
- Consult the dealer or an experienced radio/TV technician for help.

Canada

This sensor contains license-exempt transmitter(s)/receiver(s) that comply with Innovation, Science and Economic Development Canada's license-exempt RSS(s). Operation is subject to the following two conditions:

- 1.This sensor may not cause interference.
- 2.This sensor must accept any interference, including interference that may cause undesired operation of the sensor.

L'émetteur/récepteur exempt de licence contenu dans le présent appareil est conforme aux CNR d'Innovation, Sciences et Développement économique Canada applicables aux appareils radio exempts de licence. L'exploitation est autorisée aux deux conditions suivantes:

- 1.L'appareil ne doit pas produire de brouillage.**
- 2.L'appareil doit accepter tout brouillage radioélectrique subi, même si le brouillage est susceptible d'en compromettre le fonctionnement.**

This radio transmitter has been approved by Innovation, Science and Economic Development Canada to operate with the antenna types listed below, with the maximum permissible gain indicated. Antenna types not included in this list that have a gain greater than the maximum gain indicated for any type listed are strictly prohibited for use with this sensor.

Le présent émetteur radio a été approuvé par Innovation, Sciences et Développement économique Canada pour fonctionner avec les types d'antennes énumérés ci-dessous et ayant un gain admissible maximal. Les types d'antenne non inclus dans cette liste, et dont le gain est supérieur au gain maximal indiqué pour tout type figurant sur la liste, sont strictement interdits pour l'exploitation de l'émetteur.

Japan

The Bluetooth module has received type certification, and is labeled with its own technical conformity mark and certification number, as required, to conform to the technical standards regulated by the Ministry of Internal Affairs and Communications (MIC) of Japan pursuant to the Radio Act of Japan.

Certificate number 020-200037, 201-190838/00

Switzerland

For the Swiss market, our product range is registered with swissmedic and our authorised representative for Switzerland (CH-REP) is Freyr Life Sciences GmbH.



United Kingdom

For the UK market, our product range is registered with the MHRA and our authorised representative for the UK (UKRP) is I3CGLOBAL(UK) (Office 54, No.58 Peregrine Road, Hainault, IG63SZ, England).

Contact Information

For any information or Assistance, please contact:

www.k-invent.com

support@k-invent.com

Rond-Point Benjamin Franklin
34000 Montpellier, FRANCE

Release changes

KM2023A_EN	2023-05-31	Initial version
KM2023B_EN	2023-07-06	Warning and Notice Icons, BLE icon, Cleaning section, Immunity and Emissions Declarations, User Obligations
KM2023C_EN	2023-11-02	Warning and Caution re-arrange according to CER, USA Class and section added



KINVENT

MEASURE . MOVE . PROGRESS